



the cylinder pressure people

Intelligent Measuring Systems



for economic engine operation
on large bore engines

www.imes.de

IMES - Intelligent measuring systems made in Germany

IMES GmbH is the leading specialist in the field of combustion engine cylinder pressure and data acquisition systems.

IMES sensors, electronic pressure indicators and combustion control and monitoring systems are employed on a wide range of diesel, gas and dual-fuel engines, on ships and locomotives and in power and cogeneration plants and pipeline compressor stations all around the world.

IMES high quality products represent reliability, robustness, durability and long term accuracy.

The advanced data acquisition and visualisation systems allow marine, generating plant and gas compressor stations to operate cleaner, more efficiently and more reliable by reducing fuel consumption, CO2 emissions and carbon particles.



IMES GmbH founded by Stefan Neumann in 1997

Since 2012 IMES also operates its own diesel powered cogeneration plant as a research and development tool which is a significant advancement in the quality management.

Product tests can be conducted more efficiently and more quickly by simulating real engine conditions. Also development cycles for new products will be reduced.

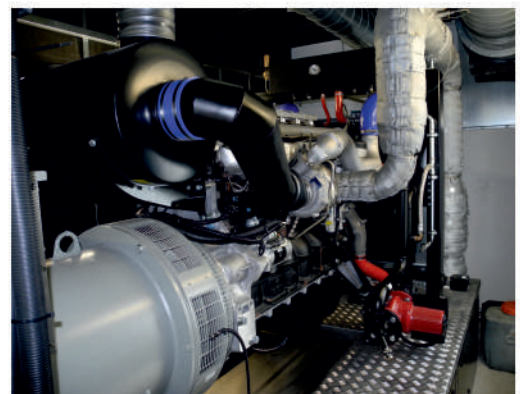

IMES diesel power cogeneration plant

Marine Type Approvals and ISO Certificate

The reason of IMES' success are the innovative products which provide an outstanding quality and know-how, as well as state-of-the-art ISO-certificated production facilities equipped with the latest manufacturing technology.



Today, large engine manufacturers are required to fulfill numerous international safety standards. Marine Type Approval is therefore a mandatory requirement for voyage and safety critical devices installed on any ship.

IMES sensor types have received Marine Type Approval from all significant international classification societies such as Bureau Veritas, DNV, ABS, GL, Lloyd's Register and NK class.

Pressure sensors from IMES - precise and durable

As one of the most basic values in combustion engine technology, cylinder pressure gives unique insights into both engine performance and engine condition.

More than 40,000 IMES TION thin film pressure sensors have been delivered to engine builders, operators of engines and compressors and manufacturers and integrators of monitoring, diagnosis and control systems.



CPS-02 and HTT-05 cylinder pressure sensors with integrated signal conditioning unit (SCU)



Cylinder pressure sensors CPS-01CA and HTT-04CA with marine type approval

Equipping each cylinder of a diesel, gas or dual-fuel engine with an IMES cylinder pressure sensor provides a vital input to electronic control, monitoring and diagnose systems and a fund of information for human analysis.

IMES cylinder pressure sensors are characterised by their long term accuracy with minimal signal drift over long periods, combined with their outstanding cost-effectiveness. Designed for a minimum of 16,000 operating hours, they enable the acquisition of highly accurate, processable data during periodic checks and during continuous monitoring of combustion pressure.

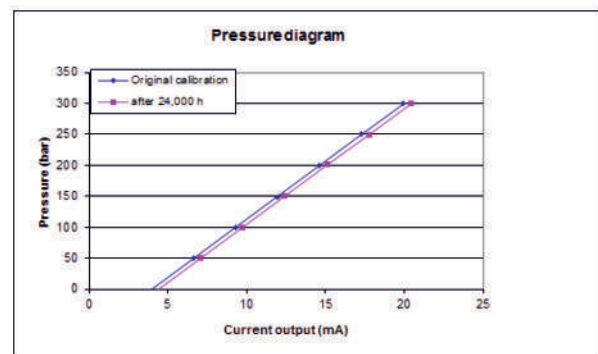



TCS-01CA - Two-stroke Combustion Sensor

The new IMES TCS-01CA sensor is designed for continuous measurement of cylinder pressure on two-stroke diesel engines. TCS-01CA is a robust, flash fitted sensor which offers outstanding longevity and constant sensitivity. Cylinder pressure measurement can be made with high precision because of its very good thermodynamic characteristics.

The TCS-01CA sensor is factory-calibrated and capable for continuous combustion pressure measurement: 24h per day / 365 days per year without any need of calibration. The measuring accuracy is 0.5% over the full measuring range and the accuracy is not influenced by any clogging or heat flash from the combustion gases.



Sensor TCS-01CA mounted on an adaptor

The IMES protection cover enables an easy mounting of TCS-01CA on the engine. It reduces vibrations and is temperature and oil resistant.

The protection cover is also available for IMES' successful sensors HTT-O4, HTT-O4CA, CPS-01 and CPS-01CA.



TCS-01CA sensor with protection cover installed on an engine

Periodic combustion monitoring on Diesel Engines

The user friendly electronic indicator EPM-XP is designed for periodic monitoring of cylinder pressure on large 2- and 4-stroke diesel engines. It can record cylinder pressure values on up to 20 cylinders on 2-stroke diesel engines operating at speeds between 40 and 300 rpm and on 4-stroke medium and highspeed diesels with rated speeds between 200 and 1500 rpm.

More than 1,300 units have been sold so far world wide and it is famous for its high accuracy, reliability and ease of use.

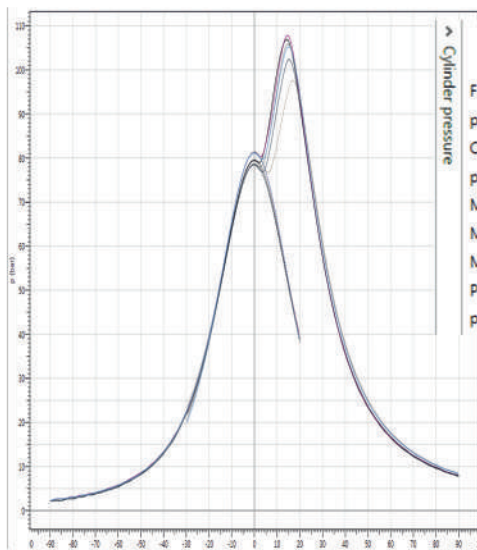

	ISO CORRECTED		MEASURED							
	REF.	CALC.	AVG.	CYL 1	CYL 2	CYL 3	CYL 4	CYL 5	CYL 6	
Firing pressure	barG	116,0 ●	108,0	104,5	107,1	108,0	97,9	106,0	102,7	105,5
pmax deviation	bar			● 2,6	● 3,5	● -6,6	● 1,5	● -1,8	● 1,0	
Compression pressure	barG	80,7 ●	81,6	80,1	79,5	81,3	81,4	78,7	78,5	81,2
pcomp deviation	bar			● -0,6	● 1,2	● 1,3	● -1,4	● -1,5	● 1,1	
Mean indicated pressure	barG	12,11		11,92	11,64	11,53	12,18	12,33	11,69	12,13
MIP deviation	bar			● -0,28	● -0,39	● 0,26	● 0,41	● -0,23	● 0,21	
Mean effective press. (MEP)	bar	11,47		11,27						
Power indicated	kW			SUM: 11039	1791	1798	1876	1898	1803	1873
pmax-pcomp pcomp / pscav	-	35,3 34,8		24,5 35,5						

The IMES visualisation software is used to analyse and process the recorded data. The software allows to calculate IPOWER and IMEP by using a mathematical algorithm.

Furthermore trending functions can be used to compare measurement data at the same engine output to find deviations in combustion process for preventive maintenance on engine.

The new IMES TPE performance evaluation software is designed to facilitate the collection, evaluation, management and comparison of engine performance data for marine diesel engines. Performance graphs and reports give a quick status of an engine and suggest actions to take for optimising engine condition. This enables extensive savings by reducing fuel and oil consumption as well as engine repairs caused by inadequately adjusted engines.

Periodic combustion monitoring on Gas Engines



EPM-XG in operation on a gas compressor

The EPM-XG gas engine balancer employs the same basic technology as the EPM-XP device for diesel engines.

EPM-XG is designed as a compact, lightweight and affordable hand-held device, specially tailored to periodic cylinder pressure monitoring and output balancing on gas engines. It delivers valuable information on engine condition. Its capabilities and functionalities are essentially similar to the EPM-XP device.

After acquisition, recorded data can be downloaded direct to a PC or notebook via USB cable. The IMES evaluation and visualisation software package is then used for analysis and further processing.

The data can also be transmitted to the pipeline operators control centre / service organisation, as major input for monitoring, diagnosis and control of the compressor station.

The EPM-XG is popular in pipeline compressor applications because of its high accuracy and ease-of-use characteristics combined with its sophisticated analysis software.



Combustion monitoring systems for Marine Diesel Engines

IMES developed CMS Marine 4-stroke portable, a multi cylinder combustion monitoring system for marine diesel engines. It is a comprehensive, transportable system which can be rapidly installed on-site and which enables the acquisition of cylinder pressure data from up to 20 cylinders on engines in the field.

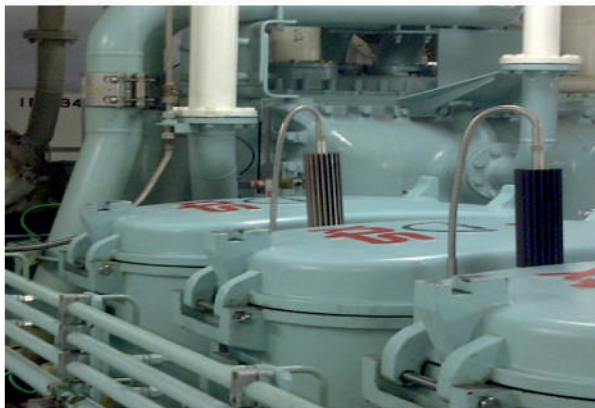

HTT-04CA sensors mounted on Thompson adaptors on a 4-stroke diesel engine

Well balanced engines effect an economy of fuel and oil consumption as well as engine repairs caused by inadequately adjusted engines. As an additional benefit emissions of the green house gas carbon can be reduced and optimised so that engines will comply with IMO TIER III limitations on NOx and SOx in Emission Control Areas (ECAs) from 2016

Periodic , simultaneous balancing of all cylinders allows to diagnose malfunctions or to assist in the setting and optimising of engine operating parameters e.g balancing cylinder.

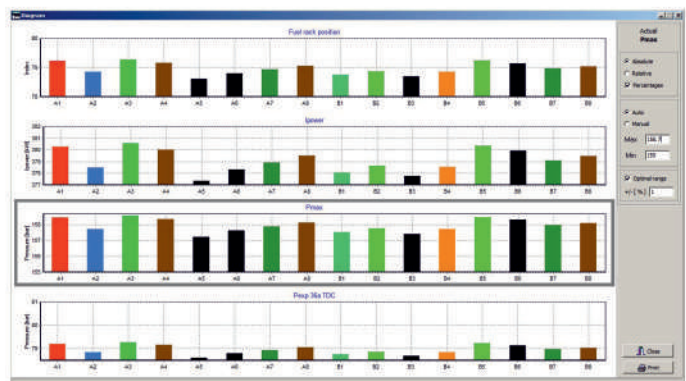

The CMS Marine PC software is a modernised version for online combustion monitoring on medium speed diesel engines.

Cylinder balancing on 2-stroke Diesel Engines

The CMS Marine 2-stroke performance system is a multi channel data acquisition for up to 12 cylinders for fixed installation with our TCS-01CA sensor on 2-stroke diesel engines. It is easy to use as an online solution for condition and performance monitoring. The combustion pressure is measured on each cylinder continuously and in parallel speed.



TCS-01CA sensor installed on a MAN&BW two-stroke engine

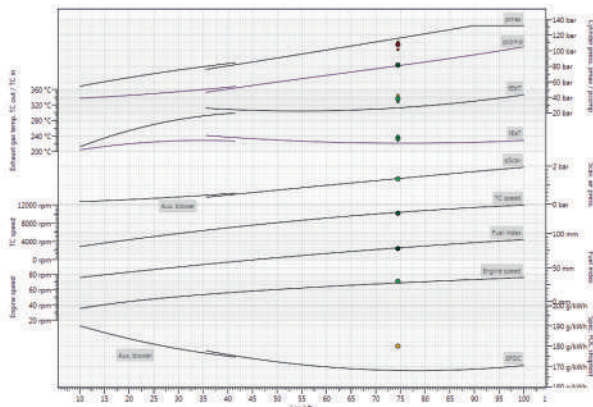

Description	Indication	Comments / recommendations
Firing press. AVG	Very low	Fuel quantity/fuel offset is set too late. / VIT is switched off. / Injection- or fuel pump valves worn. / Injection pumps and cams adjustment wrong.
Spec. FO consumption	High	Check Engine Evaluation report for saving potential. / Wrong measurement. / Wrong engine power used for calculation.
Exh. gas temp. TC in 1	High	
Firing press. (pmax) CYL 1	Very low	See Firing pressure AVG.
Firing press. (pmax) CYL 2	Low	See Firing pressure AVG.
Firing press. (pmax) CYL 3	Very low	See Firing pressure AVG.
Firing press. (pmax) CYL 4	Very low	See Firing pressure AVG.
Firing press. (pmax) CYL 5	Very low	See Firing pressure AVG.
Firing press. (pmax) CYL 6	Very low	See Firing pressure AVG.
p_max deviation CYL 2	High	
p_max deviation CYL 3	Very low	Injection- or fuel pump valves worn. / Injection pumps and cams adjustment wrong.

The CMS 2-stroke performance software allows an easy collection, management and comparison of engine performance data. Performance graphs and reports show deviation and suggest actions to take.

Clearly illustrated commercial calculations allow to save money by reducing fuel and oil consumption.



Fixed installed TCS-01CA sensors on a MAN B&W 2-stroke engine

Combustion monitoring system for Gas Engines

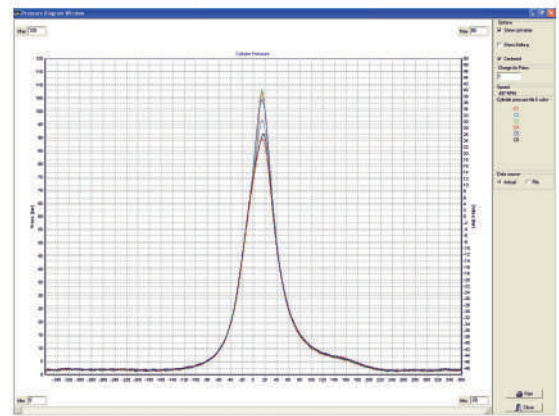

CMS Gas Engine portable is a multi cylinder combustion monitoring system for spark ignited- and dual fuel engines. It is easy to install onsite and designed for optimised adjustment of the knock detection system and optimised engine balancing.

An optimal adjusted engine enables extensive savings in gas consumption and reduces wear and tear in the engine and NOx emissions.

The CMS data acquisition module monitors and analyses up to 20 cylinders by measuring knock intensity and misfiring on each cylinder. Using CMS Gas Engine portable for the adjustment of the knock detection system is easier and more accurate than using the traditional method. The engine specific knock parameters are permanently stored in the manufacturer's engine settings.

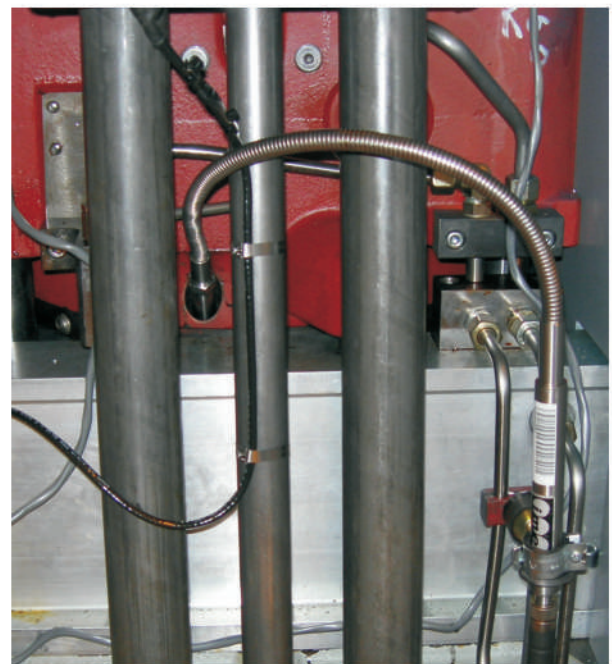

HTT-04CA sensor installed on Wärtsilä Gas Engine



Advanced pressure control on Gas Engines

CMS Gas Engine Control is designed for advanced pressure control in a closed loop system. Continuously cylinder balancing enables instant detection of combustion knock, misfire, peak pressure and IMEP.

The measured data will be transmitted from the Combustion Control Module (CCM) by CAN bus to the automation system which acts to stabilise engine operation.



Combustion Control Module (CCM)

Operation parameters can be adjusted immediately to achieve the best possible power and performance irrespective of gas quality. The misfire detection prevents incomplete combustion which makes the engine unstable and decreases the efficiency.

Optimising engine settings to improve combustion, thus minimising gas consumption and NOx emissions, based on cylinder pressure readings will become increasingly important to meet IMO Tier III emissions limits in Emissions Control Areas (ECAs).

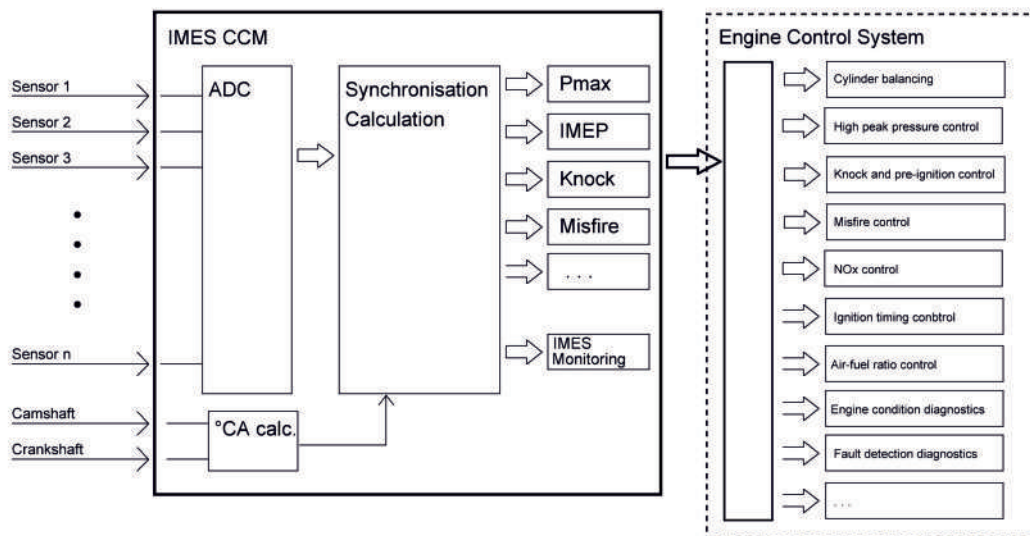

Functions of CCM and Engine Control System



We deliver worldwide!

Professional support worldwide due to our global sales organisation.

www.imes.de/sales-team.html