

Auramarine fuel supply units



**A RELIABLE CHOICE
FOR ALL SHIP TYPES**



Auramarine fuel supply units

Auramarine Heavy Fuel Oil (HFO) and Marine Gas Oil (MGO) supply units meet critical fuel circulation needs. They ensure that a fuel's condition continuously satisfies engine-specific requirements, taking care of fuel filtering, heating and cooling.

Coping with existing and future bunker regulations, and the variety of fuel blends in daily operations, can be challenging for a ship's crew and its equipment.

Auramarine offers fuel supply systems that control the injection viscosities, flow rates and fuel pressures for different fuel types and engine configurations.

All Auramarine fuel supply units are designed and manufactured to fit seamlessly into a ship's fuel system.

Our solutions comprise a standardised configuration and two extensively customisable configurations with a wide range of options and functions:

1. **AMB-Mc series 02-07: a compact, standardised solution with a select number of options for up to 10MW**
2. **AMB-M series 12-26: a customisable series for up to 25MW**
3. **AMB-M series 36-60: a customisable series for up to 60MW**

For installations over 60MW, solutions are available upon request.

Design

- compact designs enable operators to maximise revenue-generating spaces on board a vessel
- horizontal heaters ensure easy access for servicing, while vertical heaters offer compact designs
- the flexible addition of functions, during the tendering phase, can be achieved by increasing the frame size
- other individual Auramarine units can be connected to the unit later on
- front-facing pipe connections are standard and customised rear-facing pipe connection solutions are also possible

Installation

- a proven design supports fast and simple installation
- programmable logic controllers (PLC), using BUS connections, ensures reduced cable work, minimising installation costs and the risk of installation errors

Commissioning

- project-specific values are set during factory testing, which reduces the need for adjustments during commissioning
- commissioning support available

Operation

- easy operation, with all essential operational parameters visible at a glance thanks to separate instrument displays
- proven reliability and safety thanks to shell- and tube-type heaters and separate viscosity and temperature controls
- controlled via PLCs
- frequency converters can control feeder and booster pumps
- accurate fuel-consumption monitoring with BUS communication and onboard data systems enabled
- for safe and controlled fuel changeovers, Auramarine's fuel changeover system, FuelSafe™, can be integrated as a part of the configuration

Service and maintenance

- the best available components, carefully chosen materials and sophisticated manufacturing methods offer a long lifespan and flawless operation
- serviceable components are easily accessed and service space is optimised
- experienced global service and maintenance support

Main features:

- 1.** A wide range of capacities
- 2.** Multiple optional functions
- 3.** Flexible component arrangements accommodate units in the space available

Standardised units AMB-Mc 02-07



A compact, standardised Auramarine AMB-Mc fuel supply unit with a vertical heater

Main features:

- can be used to supply fuel to either main or auxiliary engines
- cost savings through standardised components
- compact design for fast and trouble-free installation
- easy maintenance: access is only required at the front and right side of the unit
- standard option comprises separate feeder and booster components

To ensure that units meet the required injection viscosities, flow rates and pressures for the various specified fuel types and engine configurations, each unit is offered independently with detailed specifications.

- **Maximum power serviceable: up to 10MW**
- **Dimensions (including service space): 1.5m x 2.9m**
- **Frame size is standardised with a few select options.**

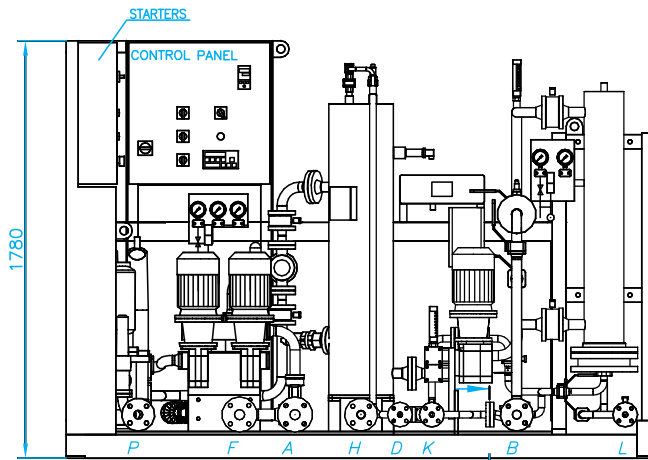
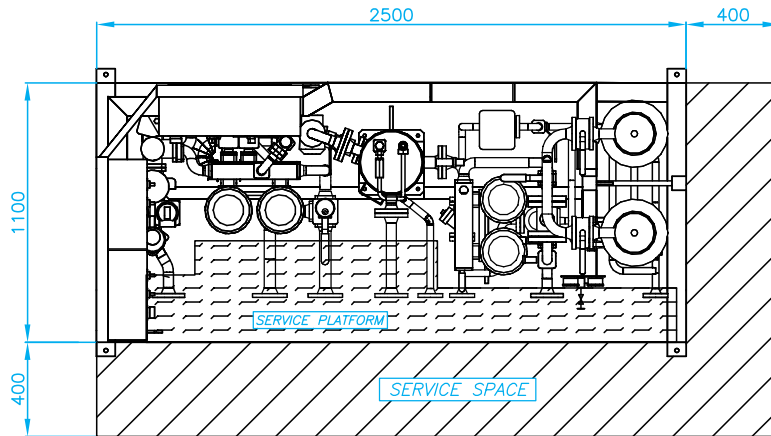

Schematic diagram of a compact, standardised Auramarine AMB-Mc fuel supply unit with a vertical heater

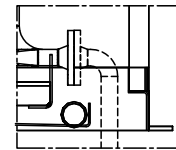

It is also possible to connect the pipes from below the unit.

A quick guide to relevant abbreviations

- MGO = marine gas oil
- HFO = heavy fuel oil
- MDO = marine diesel oil
- AMB = Auramarine feeder booster
- M, Mc, L, C, O = marine, marine compact, land, crude, offshore
- 02-07; 12-26; 36-60 = unit sizes for 2–60 MW engine(s)
- TT, SS, TE, SE, EE = heating: thermal oil, steam, thermal/electric, steam/electric, electric (if MGO is used as a fuel no heater is required)
- SSE, TTE = combination heating: 2 x steam/2 x thermal and electric heater
- LT, SW = low temperature, fresh water or sea water. Used with integrated coolers
- P, T = plate, tube cooler types
- EP = emergency pump
- MP = electrically-driven add-on pump for MGO and MDO
- F1, F2, F3 = number of additional flowmeters
- mA = milliampere/electrical current

Customer-specific solutions: AMB-M series

The two size ranges of the Auramarine M-series fuel supply units are specified depending on the engine power they will serve. They can be extensively customised to meet all customer-specific requirements. For typical options, please see page 8.

AMB-M 12-26

- Maximum power serviceable: 25MW
- Dimensions (including service space): minimum 3.60m x 2.20m
- This frame size can expand depending on optional additional features

AMB-M 36-60

- Maximum power serviceable: 60MW
- Dimensions (including service space): minimum 5.00m x 2.60m
- This frame size can expand depending on optional additional features
- For installations over 60MW, solutions are available upon request



An Auramarine AMB-M 36-60 series fuel supply unit

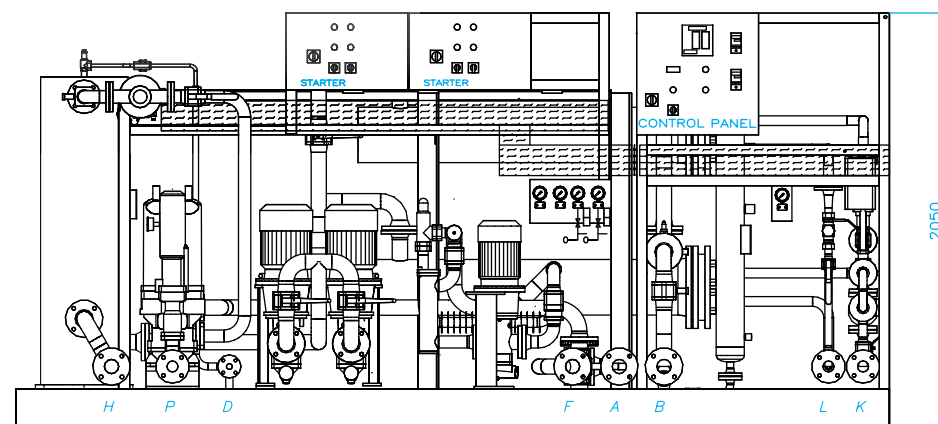

An Auramarine AMB-M 36-60 series fuel supply unit

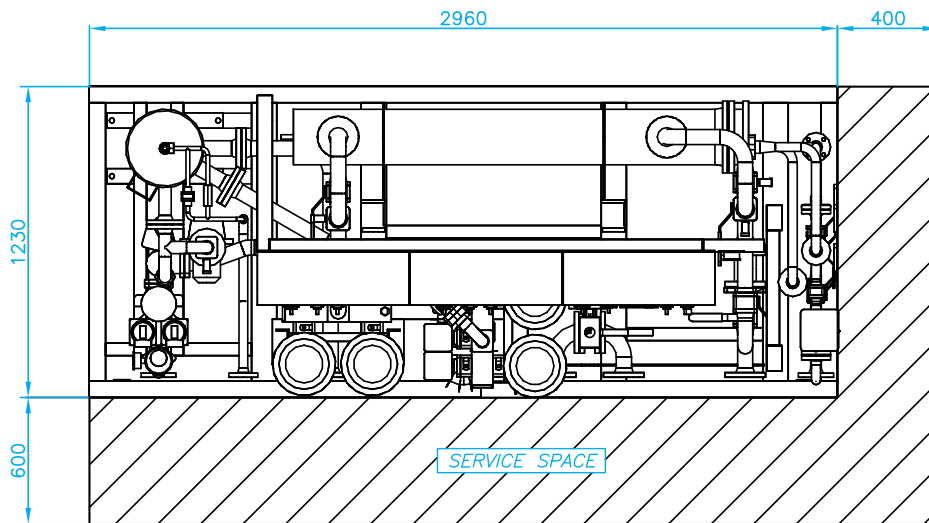
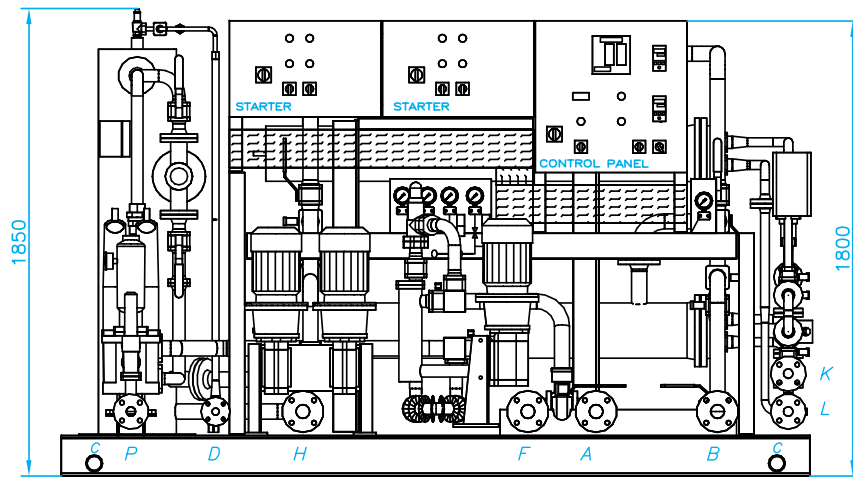

Schematic diagram of an Auramarine AMB-M 12-26 series fuel supply unit

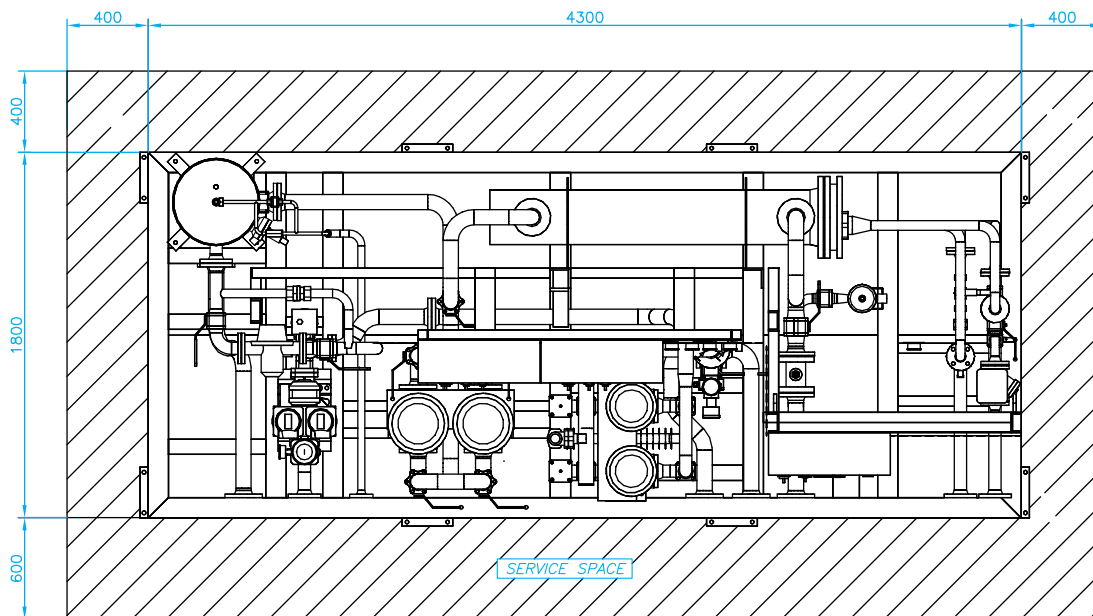

Schematic diagram of an Auramarine AMB-M 36-60 series fuel supply unit

Typical AMB-M components and options

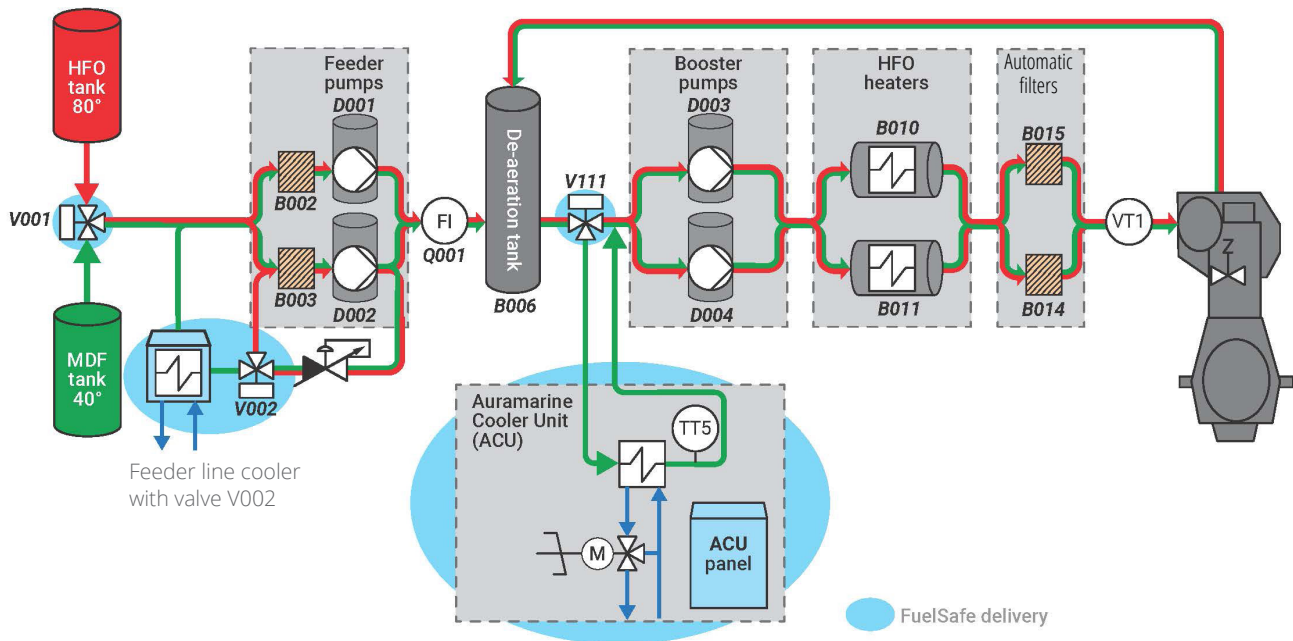

HFO/MGO 3-way changeover valve (V001) for selecting fuel and flushing the system. Changeover valves and feeder pumps can be ordered as separate units and can be remotely or manually controlled.

Suction strainers (B002, B003) for protecting the pumps.

Feeder pumps (D001, D002) for pressurising the system with fresh fuel according to the consumption requirements of the engines. They are equipped with an automatic stand-by function and have magnetic or mechanical couplings. If a separate feeder unit is ordered, the booster unit does not include feeder pumps.

Pressure control valve (V010) for maintaining constant system pressure at different loads. This is supplied with or without a bypass system.

Automatic filter with bypass filter (B014, B015) for removing impurities from fuel oil and indicating purification system failures. They are equipped with automatic cleaning and pressure-difference indicators. The degree of filtration is specified according to the engine manufacturer's recommendation or a customer's requirements.

Flowmeter (Q001) for indicating fuel consumption. Flowmeters have a local totalizer and output signal. They are available as mass or volumetric types.

Mixing tank (B006) for mixing the return fuel from the engines with fresh fuel and to help compensate for temperature and pressure changes. De-aeration is achieved manually or automatically.

Booster pumps (D003, D004) for further pressurising and circulating fuel to the engines. They can be equipped with an automatic stand-by function and have magnetic or mechanical couplings. If needed, an individual circulating pump can be delivered for each engine.

Fuel heaters (B010, B011) for heating fuel oil to the correct injection viscosity, is controlled via a viscometer. Steam heating (SS), thermal oil heating (TT) or electric heating (EE) options are available.

Viscosity control system (B016) for measuring the fuel viscosity and controlling the power of the heaters to maintain constant injection viscosity, secured by a temperature controller.

One or two MGO pumps (D005, D006) for securing a separate MGO supply to auxiliary engines while running the main engines with HFO. If a separate MGO pump unit is ordered, the booster unit does not include MGO pumps.

Auramarine Cooler Unit (ACU) for cooling fuel to the correct injection viscosity. If the cooler is built into the booster unit a separate ACU unit is not required.

If there is not enough sufficiently cool LT-water/ seawater available for the ACU-unit, or if the MDF fuel type is such that it needs to be cooled to

temperatures below 40°C to meet the minimum viscosity specified by the engine manufacturer, an **Auramarine Modular Chiller (AMC)** can be supplied as an option for additional fuel cooling.

FuelSafe™ fuel changeover system: for seamlessly switching between different fuel types. Components for an automatic FuelSafe™ fuel changeover system include a **V001 3-way valve, V002 valve and feeder line cooler, V111 valve** in line with the cooler unit, **ACU cooler unit** and **motor valve M**. For more information about FuelSafe™, see page 11.

Control panel and electrical connections

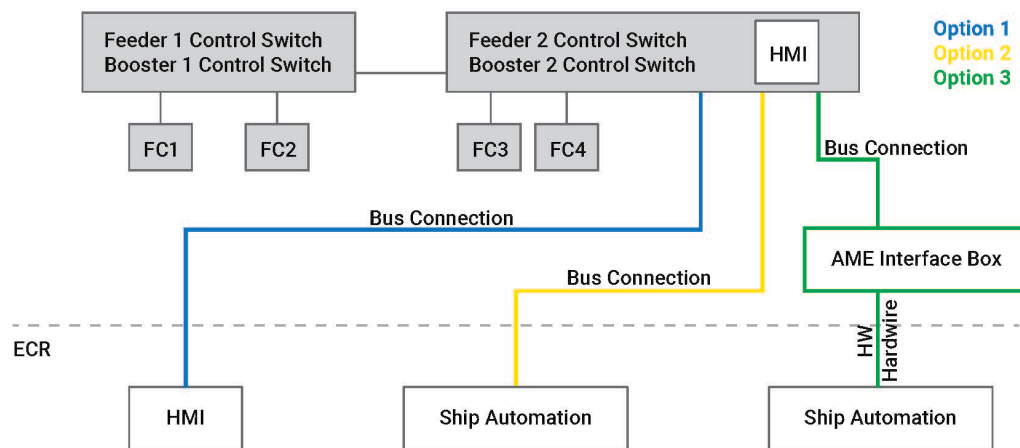

Please note: MODBUS TCP/IP are supplied as standard configurations, other BUS connection types are available as an option.

Optional features

- Viscosity signal (mA) can be relayed to the engine control room (ECR)
- Viscosity controller can be delivered separately for installation in the ECR
- Changeover valve position indication and control
- Fuel consumption signal (mA or pulse) can be relayed to the ECR
- MDO/MGO pumps can be controlled according to the type of pump chosen
- Temperature signal (mA or PT-100) can be relayed to the ECR
- Additional displays for the ECR
- Frequency converter-driven pumps
- Programmable logic controllers (PLCs)



Frequency converter for pumps



Programmable logic control (PLC)

Marine Gas Oil supply units

Auramarine fuel supply units are ideally suited for operators using single-fuel marine gas oil (MGO) or dual fuel systems. Each system is configured to meet a customer's needs and backed-up by proven long-term reliability and operational performance.

Dual fuel systems

The significantly different properties of heavy fuel oil (HFO) and low-sulphur fuels in multi-fuel systems require careful fuel condition management; an expert approach is essential. In most marine diesel engines, the viscosity of the fuel needs to be at least 2.0 cSt. The viscosity of all fuels must be stabilised and controlled through heating (HFO) or cooling (MGO). This is crucial for engine and fuel system health.

MGO systems

Low sulphur fuels, such as MGO, generally have a low viscosity and do not usually fulfil the minimum viscosity requirements of main engines. The viscosity of MGO can be increased to meet these and lubrication requirements by cooling the oil with Auramarine's ACU series of fuel oil coolers.

For operators only using MGO, heaters are not usually required, as a result, Auramarine marine feeder booster units can also be supplied without heaters.

Main features

- Auramarine's solutions for controlled cooling comprise a **cooler unit, a chilling unit when needed, and a cooling water circulation unit**. Together they enable the fuel to be cooled to temperatures below 20°C.
- For operators looking to switch to low-sulphur fuels, Auramarine MGO supply units can be fitted to both new and existing vessels.
- MGO supply units are easy and flexible to install either as independent components, or as part of a compact, integrated unit. In both cases, they optimise the use of available free space.
- Turn-key deliveries are available
- Proven design and quality components for reliable, user-friendly operation.
- Experienced global service and maintenance support.

An example configuration of an Auramarine modular chiller unit combined with an Auramarine cooler unit

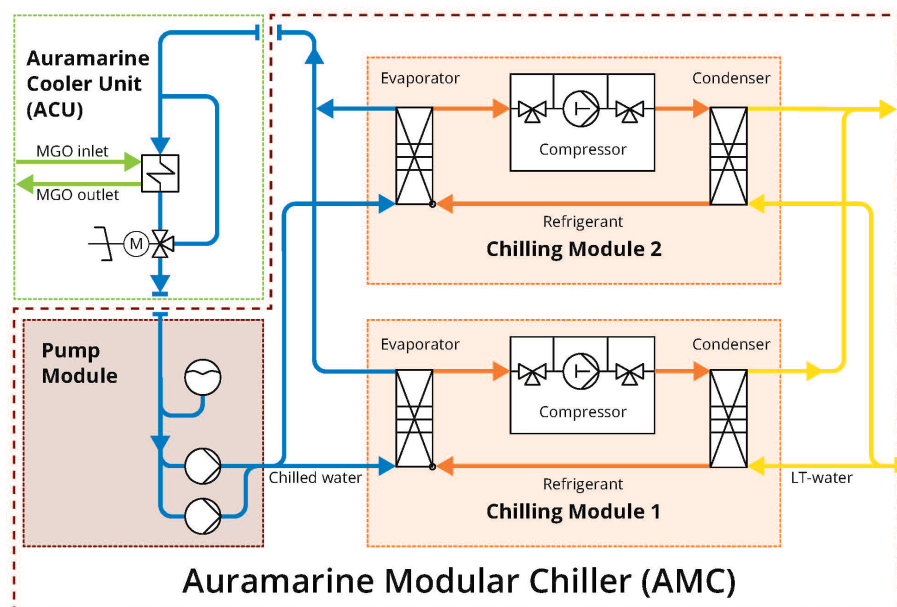

FuelSafe™ for controlled fuel changeovers

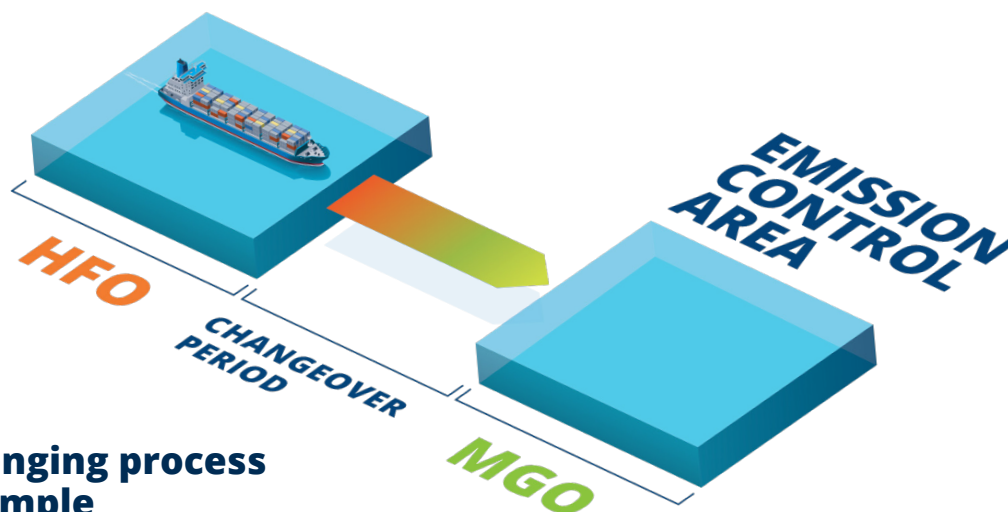

A challenging process made simple

Fuels with a wide range of properties can be used in diesel engines if these properties can be adequately controlled by the fuel handling system during the changeover process. These include, for example, high-viscosity heavy fuel oil (HFO) fuels, such as ISO 8217 standard residual fuels RMK700 or RMG380, or other high-viscosity residual fuels or blends. On the other hand, engines can use low-viscosity marine diesel fuel (MDF) fuels, such as ISO 8217 DMA, which is often referred to as MGO, or other low-viscosity fuels, such as ultra-low sulphur fuel oil (ULSFO), light fuel oil (LFO), and diesel fuel oil (DFO).

The well known challenge in instant fuel changeovers is that with a manually controlled fuel changeover system, it is almost impossible to simultaneously keep the fuel temperature change rate low enough (at a maximum rate of 2°C/min) and the viscosity high enough ($\geq 2\text{cSt}$) at the engine inlets.

- Injection pressure losses caused by too low a viscosity may result in difficulties during start-up and low-load operations.
- Too low a viscosity reduces the fuel's effectiveness as a lubricant, which can result in fuel pumps sticking and working ineffectively.

- In addition to the engine, other machinery with moving parts in the fuel-circulation system have minimum viscosity requirements. For these parts, a low viscosity can also cause malfunctions due to lubrication issues.
- Interruptions in fuel supply during the changeover process can lead to reduced engine power or in the worst case scenario, total loss of propulsion, which could be hazardous for the vessel, its crew, passengers and cargo.

Auramarine's FuelSafe™ fuel changeover solution meets all these challenges. Systems typically include an **Auramarine Fuel Selector (AFS)** and an **Auramarine Cooler Unit (ACU)**, as well as a set of key components (see figure page 8).

Changeover is initiated at the push of a button and all necessary steps are automatically controlled. It is suitable for various engine loads, fuel consumption rates and fuel system volumes; the minimum required engine load during changeover is 33%. With FuelSafe™, there is no need for a vessel to reduce its speed during the fuel changeover process.

It is ideal for both newbuilds and retrofits.

Auramarine is your trusted fuel systems expert for the marine and power industries. Our proud heritage stems from the company's foundation in Finland in the early 1970s. Since then we have delivered over 14,500 robust and reliable auxiliary systems to our customers all over the world, continuously aiming for superior service and customer value.

WE ARE THE PIONEERS IN FUEL SYSTEMS.

ID 603946

AURAMARINE LTD

P.O. Box 849 FI-20101 Turku FINLAND

+358 20 486 5030

+358 20 486 6003 (24/7 Service)

sales@auramarine.com

after.sales@auramarine.com

www.auramarine.com

